

# Conbextra GP2(N)

**Free flow , high strength, non-shrink, cementitious precision grout**

## Uses

Conbextra GP2(N) is used for precision grouting where it is essential to withstand static and dynamic loads. Typical applications would be the grouting of base plates of turbines, compressors, boiler feed pumps etc., It can also be used for anchoring a wide range of fixings. These include masts, anchor bolts and fence posts.

## Advantages

- Gaseous expansion system compensates for shrinkage and settlement in the plastic state
- No metallic iron content to cause staining
- Pre-packed material overcomes onsite batching variations
- Develops high early strength without the use of chlorides
- High ultimate strength ensure the durability of the hardened grout
- Free flow ensures high level of contact with load bearing area

## Description

Conbextra GP2(N) is supplied as a ready to use dry powder. The addition of a controlled amount of clean water produces a free flowing, non-shrink grout for gap thicknesses up to 100mm.

Conbextra GP2(N) is a blend of Portland cement, graded fillers and chemical additives which impart controlled expansion in the plastic state whilst minimising water demand. The low water demand ensures high early strength. The graded fillers are designed to assist uniform mixing and produce a consistent grout.

## Technical support

An experienced technical advisory team is available to give technical service on request.

## Properties

Compressive strength : (BS 1881 - Part 116: 1983)

Age (days)	Compressive strength (N/mm <sup>2</sup> )	
	Flowable (W/P 0.16)	Pourable (W/P 0.15)
1	24	27
3	45	54
7	55	66
28	65	78

Flexural strength ( BS 4551, 1998)

Age (days)	Flexural strength (N/mm <sup>2</sup> ) W/P 0.16
1	2.5
3	7.0
7	9.0
28	10.0

Tensile strength (W/P - 0.16) 3.5N/mm<sup>2</sup> @ 28 days

Time for expansion (after mixing ) Start : 20 minutes  
Finish : 120 minutes

Freshwet density depending on actual consistency used Approximately 2200- 2300 kg/m<sup>3</sup>

Unrestrained expansion 0 - 4 % in the plastic state enables to overcome shrinkage.

## Specification Clauses

### Performance specification

All grouting shown on the drawing must be carried out with a pre packed cement based product which is chloride free.

It shall be mixed with clean water to the required consistency. The grout must not bleed or segregate.

A positive volumetric expansion shall occur while the grout is plastic by means of gaseous system.

### Typical detail of stanchion base plate

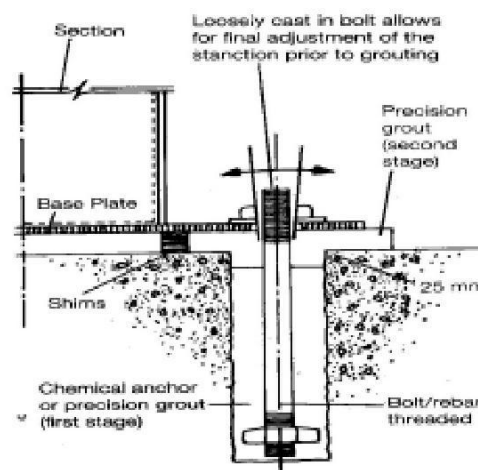

# Conbextra GP2(N)

---

The compressive strength of the grout must exceed 50 N/mm<sup>2</sup> at 7 days and 60 N/mm<sup>2</sup> at 28 days.

The flexural strength of grout must exceed 9N/mm<sup>2</sup> @ 28 days. The fresh wet density of the mixed grout must exceed 2150 kg/m<sup>3</sup>.

The storage, handling and placement of the grout must be in strict accordance with the manufacturer's instructions.

## Application instructions

### Preparation

#### Foundation surface

The substrate surface must be free from oil, grease or any loosely adherent material. If the concrete surface is defective or has laitence, it must be cut back to a sound base. Bolt holes and fixing pockets must be blown clean of any dirt or debris.

#### Pre-soaking

Several hours prior to placing, the concrete substrates should be saturated with fresh water.

Immediately before grouting takes place any free water should be removed with particular care being taken to blow out all bolt holes and pockets.

#### Base plate

It is essential that this is clean and free from oil, grease or scale. Air pressure relief holes should be provided to allow venting of any isolated high spots.

#### Levelling shims

If these are to be removed after the grout has hardened, they should be treated with a thin layer of grease.

#### Formwork

The formwork should be constructed to be leakproof. This can be achieved by using foam rubber strip or mastic sealant beneath the constructed formwork and between joints.

In some cases it is practical to use a sacrificial semi-dry sand and cement formwork. The formwork should include outlets for pre-soaking.

#### Unrestrained surface area

This must be kept to a minimum. Generally the gap width between the perimeter formwork and the plate edge should not exceed 150mm on the pouring side and 50mm on the opposite side. It is advisable, where practical, to have no gap at the flank sides.

## Mixing and placing

### Mixing

For best results a mechanically powered grout mixer should be used. When quantities up to 50kg are used, a heavy duty slow speed drill (400-500 rpm) fitted with a paddle is suitable..

Larger quantities will require a heavy duty mixer.

To enable the grouting operation to be carried out continuously, it is essential that sufficient mixing capacity and labour are available. The use of a grout holding tank with provision to gently agitate the grout may be required.

### Consistency of grout mix

The quantity of clean water required to be added to a 30kg bag to achieve the desired consistency is given below :

Pourable : 4.5 litres

Flowable : 4.8 litres

The selected water content should be accurately measured into the mixer. The total content of the Conbextra GP2(N) bag should be slowly added and continuous mixing should take place for 5 minutes. This will ensure that the grout has a smooth even consistency.

### Placing

At 30<sup>0</sup>C place the grout within 20 minutes of mixing to gain full benefit of the expansion process.

Conbextra GP2(N) can be placed in thicknesses up to 100mm in a single pour when used as an underplate grout.

For thicker sections it is necessary to fill out Conbextra GP2 (N) with well graded silt free aggregate to minimise heat build up. Typically a 10mm aggregate is suitable. 50 - 100% aggregate by weight of Conbextra GP2(N) can be added.

Any bolt pockets must be grouted prior to grouting between the substrate and the base plate.

Continuous grout flow is essential. Sufficient grout must be prepared before starting. The time taken to pour a batch must be regulated to the time to prepare the next one.



# Conbextra GP2(N)

## Typical hopper system

**Removable hopper** : For large pours the grout may be hand placed or pumped into a removable hopper ( trough)

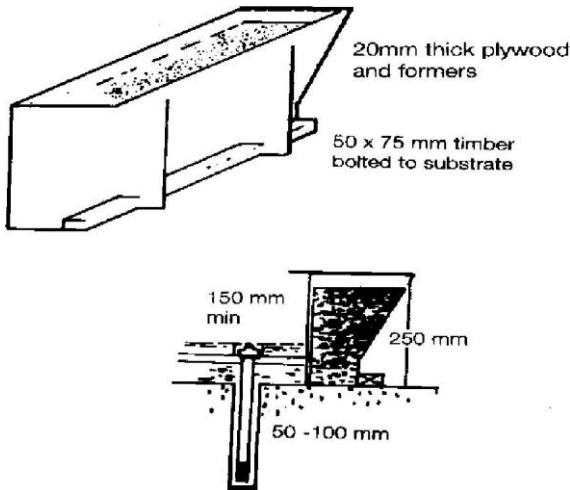

Pouring should be from one side of the void to eliminate any air or presoaked water becoming trapped under the base plate. It is advisable to pour the grout across the shortest distance of travel. The grout head must be maintained at all times so that a continuous grout front is achieved.

Where large volumes have to be placed Conbextra GP2(N) may be pumped. A heavy duty diaphragm pump is recommended for this purpose. Screw feed and piston pumps may also be suitable.

## Curing

On completion of the grouting operation, exposed areas should be thoroughly cured. This should be done by the use of Concure WB curing membrane, continuous application of water and/or wet hessian.

## Limitations

### Low temperature working

When the air or contact surface temperatures are  $10^{\circ}\text{C}$  or below on a falling thermometer, warm water (  $30 - 40^{\circ}\text{C}$ ) is recommended to accelerate strength development.

For ambient temperature below  $10^{\circ}\text{C}$  the formwork should be kept in place for at least 36 hours.

Normal precautions for winter working with cementitious materials should then be adopted.

### High temperature working

At ambient temperatures above  $40^{\circ}\text{C}$ , cool water (below  $20^{\circ}\text{C}$ ) should be used for mixing the grout prior to placement.

## Estimating

### Packaging

Conbextra GP2(N) is supplied in 30 kg moisture resistant bags.

### Yield

Allowance should be made for wastage when estimating quantities required. The approximate yield per 30 kg bag for different consistency is :

Consistency	Pourable	Flowable
Yield ( litres)	15.6	15.8

## Storage

### Shelf life

Conbextra GP2 (N) has a shelf life of 6 months if kept in a dry store in sealed bags. If stored in high temperature and high humidity locations, the shelf life may be reduced.

## Precautions

### Health and Safety instructions

Conbextra GP2(N) is alkaline and should not come into contact with skin and eyes. Inhalation of dust during mixing should be avoided.

Gloves, goggles and dust mask should be worn.

If contact with skin occurs, it shall be washed with water. Splashes to eyes should be washed immediately with plenty of clean water and medical advice sought.

# Conbextra GP2(N)

---

## Fire

Conbextra GP2(N) is non flammable.

## Additional information

For further details about the use and selection of grouts refer to the Fosroc Information module entitled 'Precision grouting in the Construction industry'.



## Fosroc Chemicals (India) Pvt. Ltd.

### Head Office

"Sapthagiri Palace",  
No.38, II & III Floor, 12th  
Cross, CBI Road, Ganganagar  
North, Bangalore 560 032

### Important note :

Fosroc products are guaranteed against defective materials and manufacture and are sold subject to its standard terms and conditions of sale, copies of which may be obtained on request. Whilst Fosroc endeavours to ensure that any advice, recommendation specification or information it may give is accurate and correct, it cannot, because it has no direct or continuous control over where or how its products are applied, accept any liability either directly or indirectly arising from the use of its products whether or not in accordance with any advice, specification, recommendation or information given by it.

### telephone

++91 80-42521900

### fax

++91 80-23551510

### e-mail

enquiryindia@fosroc.com

### Regional Offices

#### Chennai

No. 26(old no.33), 1st Floor,  
1st Street Postal Colony,  
West Mambalam,  
Chennai 600 033.  
Ph: 044-24899949-94  
Fax: 044-24896641

#### Mumbai

1401/1402, 14th Floor,  
A-Wing 'The Great Eastern Summit'  
Sector-15, CBD, Belapur  
Navi Mumbai 400 614  
Ph: 022-43406800-04  
Fax: 022-27562423

#### Noida

D-166 Sector 10  
Noida,  
UP 201 301  
Ph:0120-4270620-21  
Fax: 0120-4270622

#### Kolkata

304, Jodhpur Park  
Kolkata 700 068  
Ph:033-65343188  
Fax: 033-2499-0280